

ITEM NO.	DESCRIPTION	WKI-1001 & GG 550	QTY. PER UNIT
1	STOPPER	174C068P01	1
MOUNT ASSEMBLY			
*2	SPLASH GUARD	614C069P01	1
*3	SINKFLANGE & CAP ASSEMBLY	249C014S83	1
*4	RUBBER GASKET	269C031P01	1
*5	FIBER GASKET (WAXED)	269C033P01	1
*6	SUPPORT RING	614C072P01	1
*7	MOUNT RING	614C059P02	1
*8	CUSHION MOUNT RING	469C004P02	1
9	OUTLET SCREW	636C017P03	2
10	OUTLET FLANGE	249C009P01	1
11	OUTLET ELBOW	673C015P01	1
12	RUBBER OUTLET GASKET	269C038P01	1
DRAIN HOUSING ASSEMBLY - 100V			
DRAIN HOUSING ASSEMBLY - 240V			
*13	GRIND RING	614C066P02	1
*14	DRAIN HOUSING	311C080P01	1
*15	THRUST WASHER	789C041P01	1
*16	WATER SEAL	645C006P01	1
*17	SPACER SEAL	102C005P01	1
18	SLINGER	789C034P03	1
19	O-RING	645C004P01	1
20	TURNTABLE ASSEMBLY	258C032S02	1
21	HOPPER (SHORT)	311C077S01	1
22	HOPPER SCREW	636C023P01	4
23	WASHER	789C035P02	1
24	ARMATURE ASSEMBLY - 100V	626C035P06	1
24	ARMATURE ASSEMBLY - 220-240V	626C038P02	1
25	MOTOR STUD	687C003P04	2
26	MOTOR SHELL ASSEMBLY - 100V	681C031S13	1
26	MOTOR SHELL ASSEMBLY - 220-240V	681C031S23	1
ENDBELL ASSEMBLY - 100V			
ENDBELL ASSEMBLY - 220-240V			
ENDBELL ASSEMBLY - 220-240V (BEAB ONLY)			
*27	ENDBELL - 100V	311C081S52	1
*27	ENDBELL - 220-240V	311C084S52	1
*28	MOTOR BRUSH & BRUSH SPRING ASSY - 100V	027C029S02	1
*28	MOTOR BRUSH & BRUSH SPRING ASSY - 220-240V	027C029S01	1
29	NUT	479C019P01	2
30	NUT	479C021P01	2
31	SHELL SCREW (SHORT)	636C029P02	3
32	LOWER SHELL (SHORT)	806C044P03	1
33	RFI FILTER - 100V	245C008S02	1
33	RFI FILTER - 220-240V	245C008S51	1

..... †NOT SHOWN *PART OF AN ASSEMBLY, BUT CAN BE PURCHASED SEPARATELY.

Anaheim Disposers

International 1/2 HP

WKI-1001 & GG 550

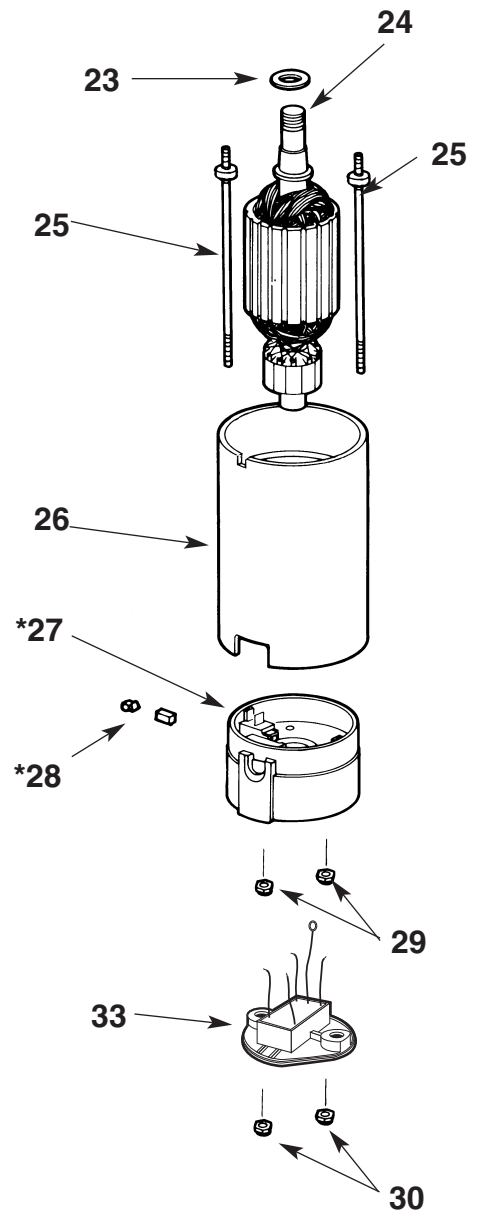
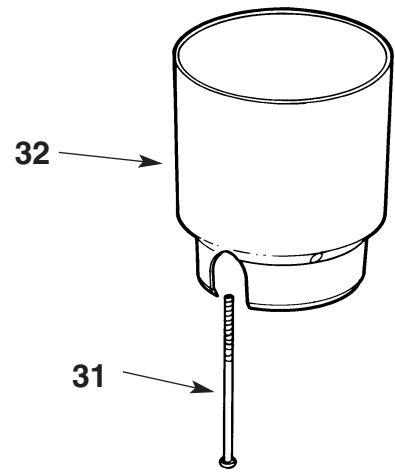
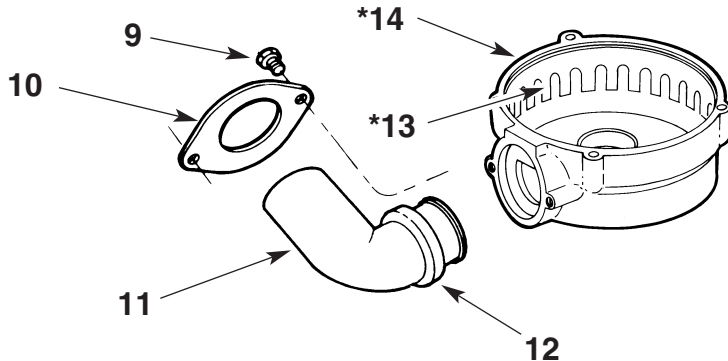
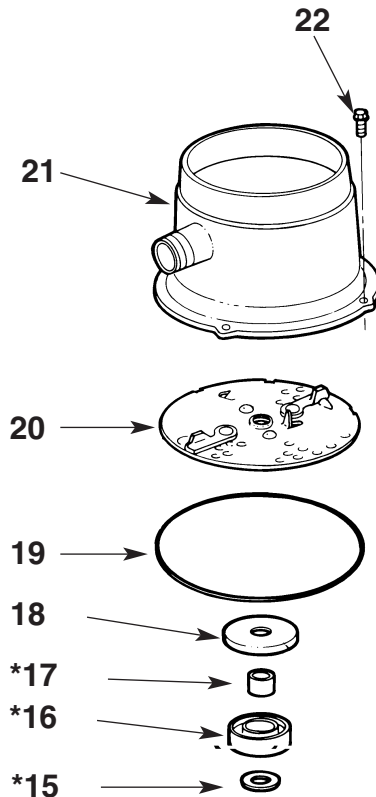
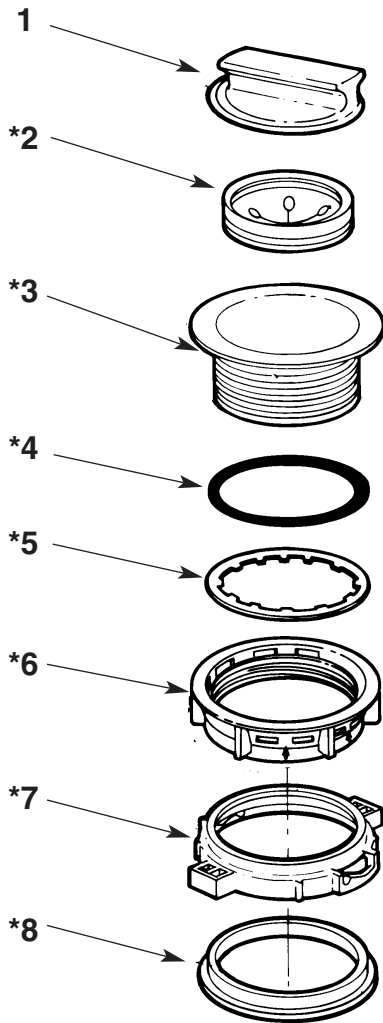

P.O. BOX 4146
ANAHEIM, CA 92803 U.S.A.

* PART OF AN ASSEMBLY, BUT CAN BE PURCHASED SEPARATELY.

ITEM NO.	DESCRIPTION	WKI-2600 & GG 750	QTY. PER UNIT
1	.STOPPER	.174C068P01	1
MOUNT ASSEMBLY		.249C019S41	1
*2	.SPLASH GUARD	.614C069P01	1
*3	.SINKFLANGE & CAP ASSEMBLY.	.249C014S01	1
*4	.RUBBER GASKET	.269C031P01	1
*5	.FIBER GASKET (WAXED)	.269C033P01	1
*6	.SUPPORT RING	.614C072P01	1
*7	.MOUNT RING	.614C059P02	1
*8	.CUSHION MOUNT RING	.469C004P02	1
9	.OUTLET SCREW	.636C017P03	2
10	.OUTLET FLANGE	.249C009P01	1
11	.OUTLET ELBOW	.673C015P01	1
12	.RUBBER OUTLET GASKET	.269C038P01	1
DRAIN HOUSING ASSEMBLY - 100V		.311C080S02	1
DRAIN HOUSING ASSEMBLY - 220-240V		.311C080S22	1
*13	.GRIND RING	.614C066P02	1
*14	.DRAIN HOUSING.	.311C080P01	1
*15	.THRUST WASHER	.789C041P01	1
*16	.WATER SEAL	.645C006P01	1
*17	.SPACER SEAL	.102C005P01	1
18	.SLINGER	.789C034P04	1
19	.O-RING	.645C004P01	1
20	.TURNTABLE ASSEMBLY	.258C032S02	1
21	.HOPPER	.311C076S01	1
22	.HOPPER SCREW	.636C023P01	4
23	.WASHER	.789C035P02	1
24	.ARMATURE ASSEMBLY -100V	.626C035P06	1
24	.ARMATURE ASSEMBLY -220-240V	.626C038P02	1
25	.STUD MOTOR	.687C003P04	2
26	.MOTOR SHELL ASSEMBLY -100V	.681C031S12	1
26	.MOTOR SHELL ASSEMBLY - 220-240V	.681C031S22	1
ENDBELL ASSEMBLY - 100V		.311C081S105	1
ENDBELL ASSEMBLY - 220-240V		.311C084S31	1
ENDBELL ASSEMBLY - 220-240V (BEAB ONLY)		.311C084S31	1
*27	.ENDBELL - 100V	.311C081S52	1
*27	.ENDBELL - 220-240V	.311C084S52	1
*28	.BRUSH MOTOR & BRUSH SPRING ASSY - 100V	.027C029S02	1
*28	.BRUSH MOTOR & BRUSH SPRING ASSY - 220-240V	.027C029S01	1
29	.NUT	.479C019P01	2
30	.NUT	.479C021P01	2
31	.UPPER SHELL	.806C067P01	1
32	.LOWER SHELL	.806C068P01	1
33	.SHELL SCREW	.636C014P19	3
34	.RFI FILTER - 100V	.245C008S02	1
34	.RFI FILTER - 220-240V	.245C008S01	1

†NOT SHOWN *PART OF AN ASSEMBLY, BUT CAN BE PURCHASED SEPARATELY.

Anaheim Disposers

International 1/2 HP

WKI-2600 & GG 750

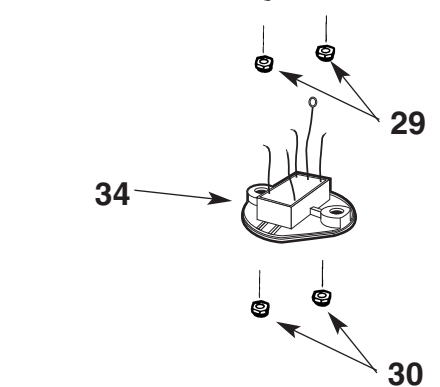
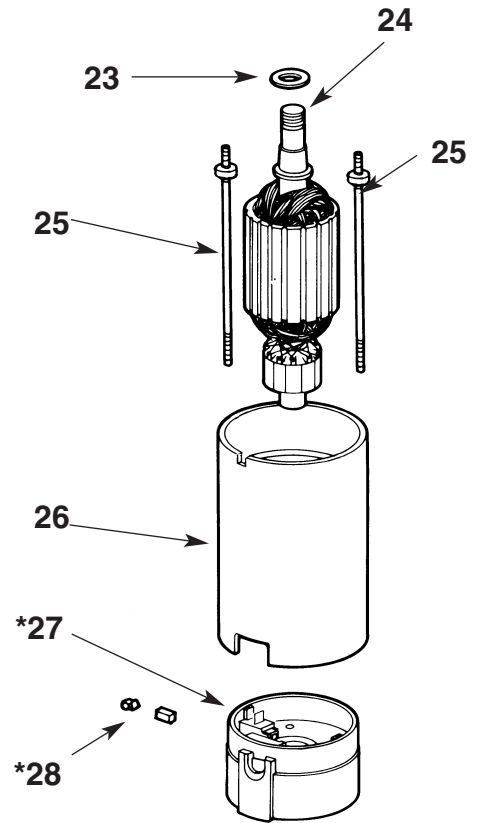
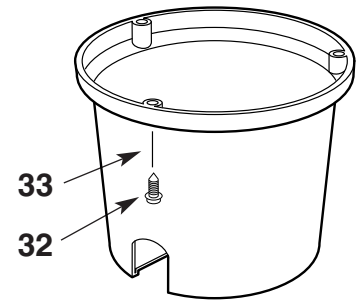
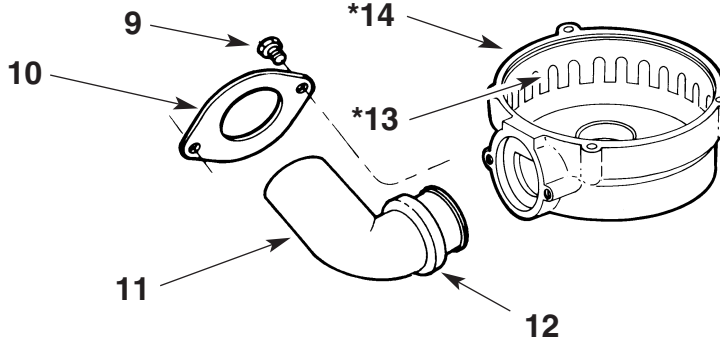
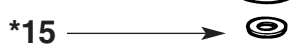
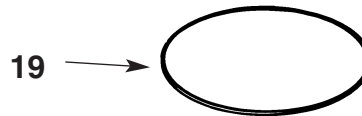
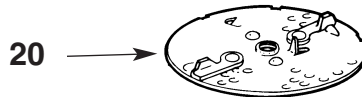
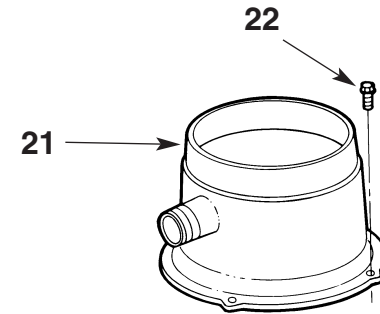
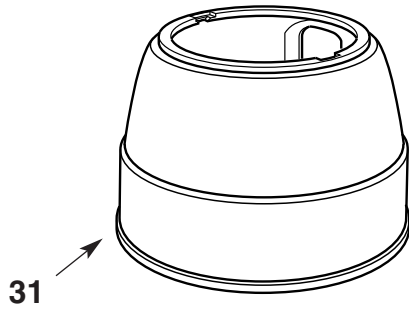
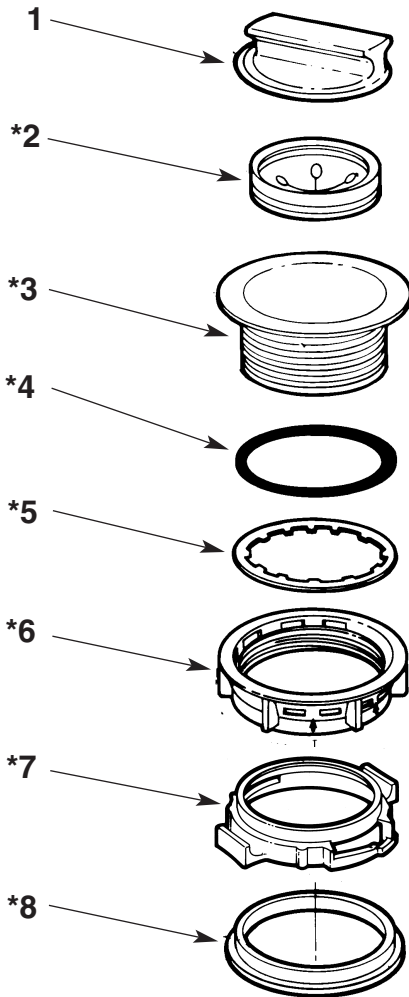

P.O. BOX 4146
ANAHEIM, CA 92803 U.S.A.

* PART OF AN ASSEMBLY, BUT CAN BE PURCHASED SEPARATELY.

WKI-2600TC & GG BF750 BATCH FEED

ITEM #	DESCRIPTION	PART #	QTY	ITEM #	DESCRIPTION	PART #	QTY
	MOUNT ASSEMBLY	.249C019S412BF	.1	31	..NUT	.479C019P01	.2
*1	..STOPPER	.174C066S02	.1	32	..INSPECTION PLATE	.554C032P01	.1
*2	..SINKFLANGE & CAP ASSY.	.249C014S35	.1	33	..NUT	.479C021P01	.1
*3	..RUBBER GASKET	.269C031P01	.1	34	..UPPER SHELL	.806C067P51	.1
*4	..FIBER GASKET (WAXED)	.269C033P01	.1	35	..LOWER SHELL	.806C068P01	.1
*5	..SUPPORT RING	.614C072P01	.1	36	..SHELL SCREW	.636C014P19	.3
*6	..MOUNT RING	.614C059P02	.1	37	..PLUNGER BUTTON	.106C004P01	.1
*7	..CUSHION MOUNT RING	.469C004P02	.1	38	..”O” RING	.614C027P01	.2
8	..OUTLET SCREW	.636C017P03	.2	39	..BUSHING	.102C003P02	.1
9	..OUTLET FLANGE	.249C009P01	.1	40	..”O” RING	.614C028P01	.1
10	..OUTLET ELBOW	.673C015P01	.1	41	..SCREW	.636C026P01	.4
11	..RUBBER OUTLET GASKET	.269C038P01	.1	42	..COLLAR	.154C005P02	.1
12	..GRIND RING	.614C066P02	.2	43	..SWITCH COVER	.174C021P01	.1
	DRAIN HOUSING ASSEMBLY - 100V	.311C080S02	.1	44	..SCREW	.636C014P03	.3
	DRAIN HOUSING ASSEMBLY - 240V	.311C080S22	.1	45	..SCREW	.636C019P01	.2
*13	..DRAIN HOUSING	.311C080P01	.1	46	..CHERRY SWITCH	.695C003P02	.1
*14	..THRUST WASHER	.789C041P01	.1	47	..SWITCH BRACKET	.072C001P01	.1
*15	..WATER SEAL	.645C006P01	.1	48	..JAM NUT	.479C010P01	.1
*16	..SPACER SEAL	.102C005P01	.1	49	..SPRING	.675C001P01	.1
	TURNTABLE ASSEMBLY	.258C032S02	.1	50	..WASHER	.789C011P01	.1
*17	..SLINGER	.789C034P03	.1	51	..WASHER	.789C013P01	.1
*18	..O-RING	.645C004P01	.1	52	..RETAINER	.612C007P01	.1
*19	..TURNTABLE	.258C032S02	.1	53	..BUSHING	.287C002P01	.1
20	..HOPPER ASSEMBLY	.311C076S01	.1	54	..BUSHING	.102C004P01	.2
21	..HOPPER SCREW	.636C023P01	.4	55	..CONNECTOR FLAG	.711C010P01	.2
22	..ADAPTER	.614C061P02	.1	56	..CONDUIT CLAMP	.142C001P01	.1
23	..GASKET	.269C014P01	.1	57	..SCREW	.636C015P18	.1
24	..WASHER	.789C035P02	.1	58	..CONDUIT	.163C003P02	.1
25	..ARMATURE ASSEMBLY - 100V.	.626C035P03	.1	59	..LEAD WIRE (WHITE)	.299C008P11	.1
25	..ARMATURE ASSEMBLY - 240V.	.626C038P02	.1	60	..LEAD WIRE (WHITE)	.299C008P10	.1
26	..MOTOR STUD	.687C003P01	.1	61	..SPLICE	.711C009P01	.1
27	..MOTOR STUD	.687C003P02	.1	62	..GROUND WIRE	.299C005S07	.1
28	..MOTOR SHELL ASSEMBLY - 100V	.681C031S13	.1	63	..CONDUIT CLAMP	.142C002P01	.1
28	..MOTOR SHELL ASSEMBLY - 240V	.681C031S23	.1	64	..SCREW	.636C014P18	.1
	ENDBELL ASSEMBLY - 100V	.311C081S107	.1	†65	..RFI FILTER - 100V	.245C008S02	.1
	ENDBELL ASSEMBLY - 240V	.311C084S35	.1	†65	..RFI FILTER - 240V	.245C008S51	.1
*29	..ENDBELL	.311C081S53	.1				
*30	..MTR. BRUSH & BRUSH SPRING ASSY	.027C029S02	.1				

†NOT SHOWN

*PART OF AN ASSEMBLY, BUT CAN BE PURCHASED SEPARATELY.

Anaheim Disposers

International 1/2 HP BATCH FEED WKI-2600TC & GG BF750

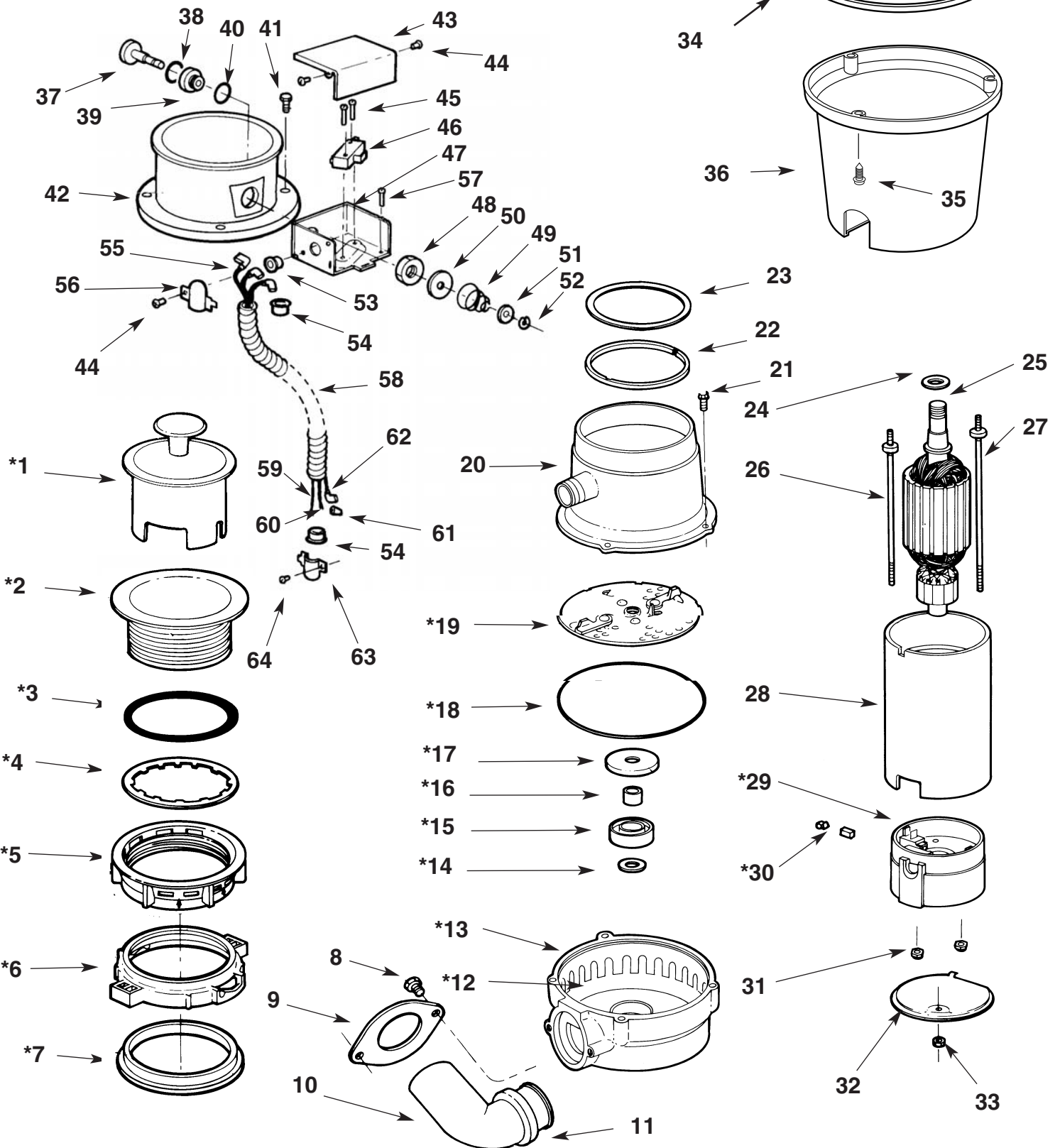

P.O. BOX 4146
ANAHEIM, CA 92803 U.S.A.

* PART OF AN ASSEMBLY, BUT CAN BE PURCHASED SEPARATELY.

ITEM NO.	DESCRIPTION	WKI-3300 & GG 950	QTY. PER UNIT
1	STOPPER	.174C049S01	1
MOUNT ASSEMBLY		.249C019S41	1
*2	SPLASH GUARD	.614C069P01	1
*3	SINKFLANGE & CAP ASSEMBLY	.249C014S01	1
*4	RUBBER GASKET	.269C031P01	1
*5	FIBER GASKET (WAXED)	.269C033P01	1
*6	SUPPORT RING	.614C072P01	1
*7	MOUNT RING	.614C059P02	1
*8	CUSHION MOUNT RING	.469C004P02	1
9	OUTLET SCREW	.636C017P03	2
10	OUTLET FLANGE	.249C009P01	1
11	OUTLET ELBOW	.673C015P01	1
12	RUBBER OUTLET GASKET	.269C038P01	1
13	GRIND RING	.614C060P01	1
DRAIN HOUSING ASSEMBLY - 100V		.311C082S01	1
DRAIN HOUSING ASSEMBLY - 240V		.311C082S21	1
14	DRAIN HOUSING	.311C082P01	1
*15	THRUST WASHER	.789C041P01	1
*16	WATER SEAL	.645C006P01	1
*17	SPACER SEAL	.102C005P01	1
18	SLINGER	.789C034P03	1
19	O-RING	.645C005P01	1
20	TURNTABLE ASSEMBLY	.258C032S04	1
21	HOPPER	.311C070S01	1
22	HOPPER SCREW	.636C023P01	6
23	WASHER	.789C035P02	1
24	ARMATURE ASSEMBLY - 100V	.626C035P07	1
24	ARMATURE ASSEMBLY - 220-240V	.626C038P03	1
25	MOTOR STUD	.687C003P05	2
26	MOTOR SHELL ASSEMBLY - 100V	.681C031S14	1
26	MOTOR SHELL ASSEMBLY - 220-240V	.681C031S24	1
ENDBELL ASSEMBLY - 100V		.311C081S106	1
ENDBELL ASSEMBLY - 220-240V		.311C084S32	1
ENDBELL ASSEMBLY - 220-240V (BEAB ONLY)		.311C084S32	1
*27	ENDBELL - 100V	.311C081S52	1
*27	ENDBELL - 220-240V (BEAB)	.311C084S52	1
*28	BRUSH MOTOR & BRUSH SPRING ASSEMBLY - 100V	.027C029S02	1
*28	BRUSH MOTOR & BRUSH SPRING ASSEMBLY - 220-240V	.027C029S01	1
29	NUT	.479C019P01	2
30	NUT	.479C021P01	2
31	UPPER SHELL	.806C064P61	1
32	LOWER SHELL	.806C065P01	1
33	SHELL SCREW	.636C014P19	3
†34	SINKFLANGE GASKET-WAXED (THICK)	.269C032P01	1
35	RFI FILTER - 100V	.245C008S02	1
35	RFI FILTER - 220-240V	.245C008S52	1

†NOT SHOWN *PART OF AN ASSEMBLY, BUT CAN BE PURCHASED SEPARATELY.

Anaheim Disposers

INTERNATIONAL 3/4 HP

WKI-3300 & GG 950

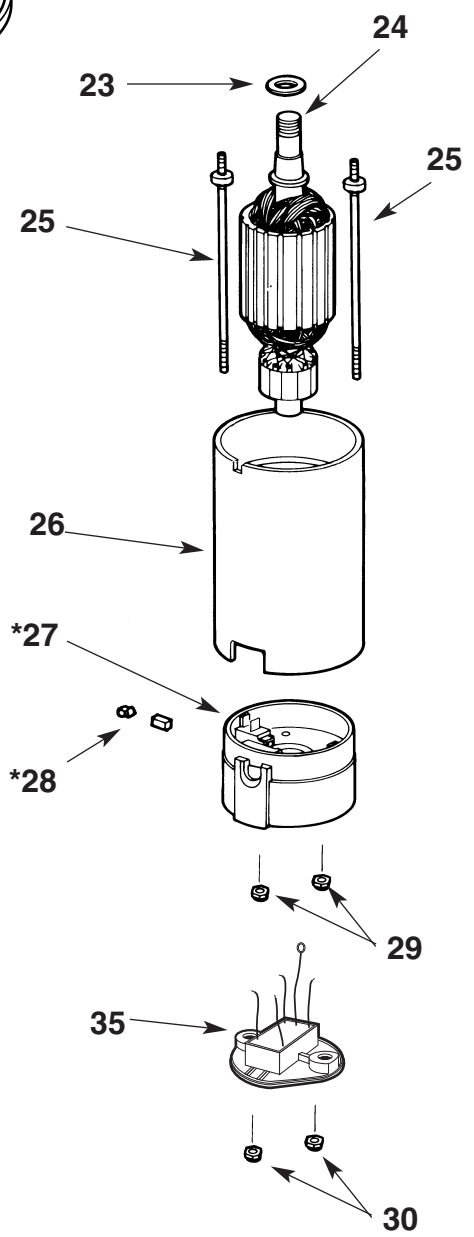
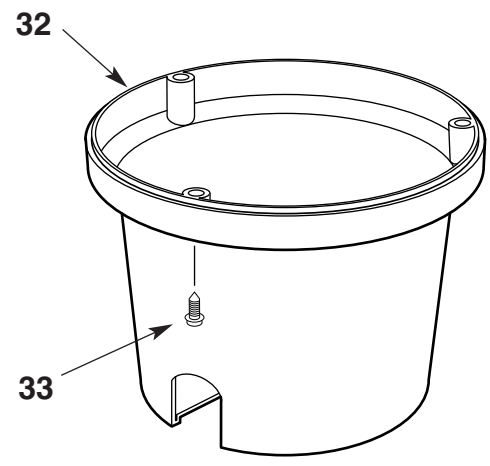
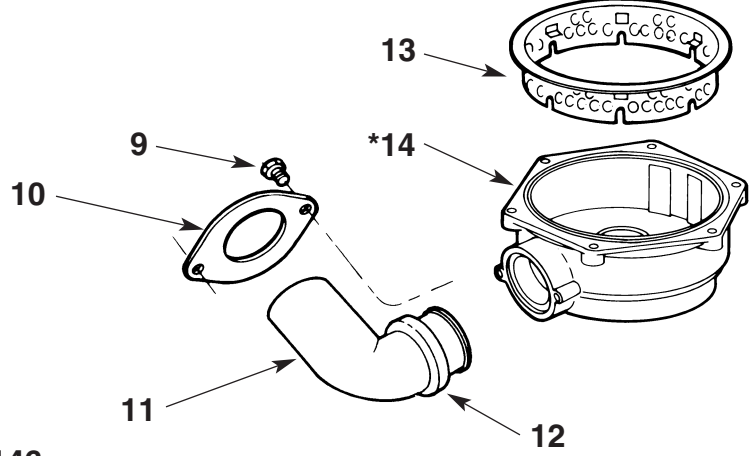
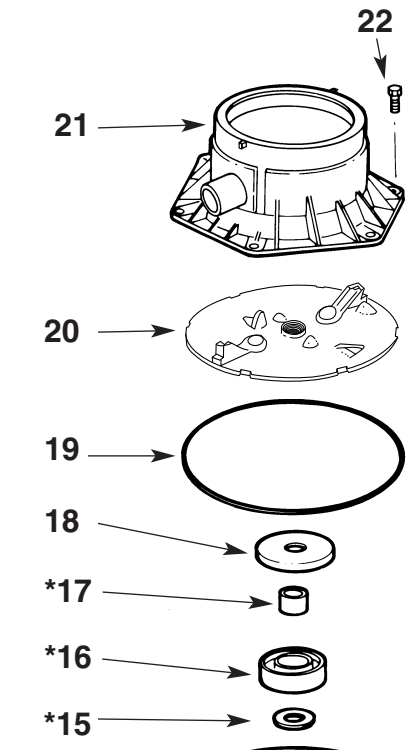
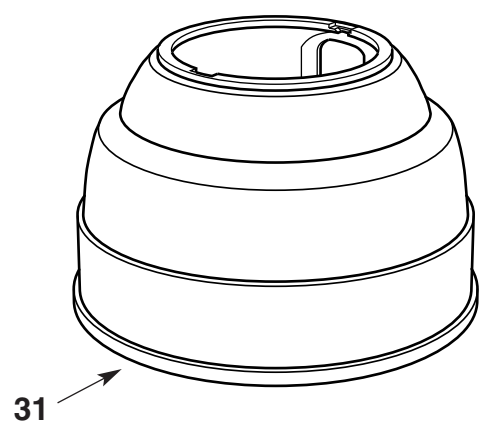
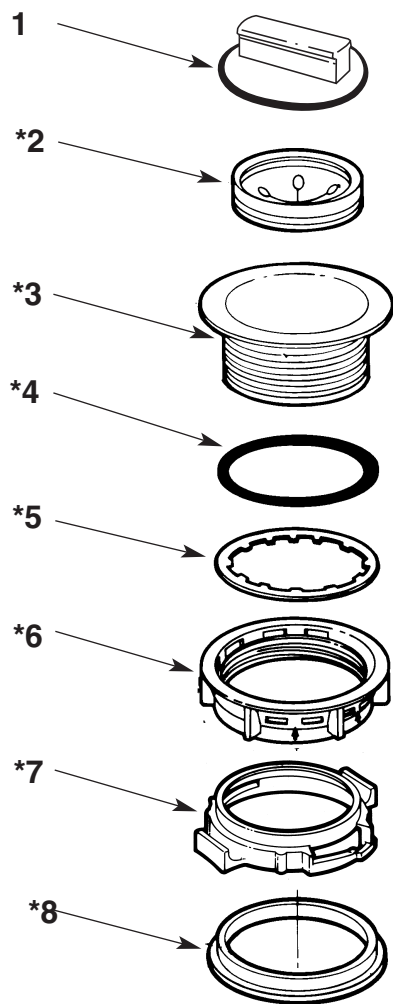

P.O. BOX 4146
ANAHEIM, CA 92803 U.S.A.

* PART OF AN ASSEMBLY, BUT CAN BE PURCHASED SEPARATELY.

WKI-5000TC & GG BF950 BATCH FEED

ITEM #	DESCRIPTION	PART #	QTY	ITEM #	DESCRIPTION	PART #	QTY
1	STOPPER ASSY	174C066S02	1	30	NUT	479C021P01	2
	MOUNT ASSEMBLY	249C019S41BF	1	31	NUT	479C019P01	2
*2	SINKFLANGE & CAP ASSY.	249C014S01	1	32	UPPER SHELL	806C064PXX (reference)	1
*3	RUBBER GASKET	269C031P01	1	33	LOWER SHELL	806C065PXX (reference)	1
*4	FIBER GASKET (WAXED)	269C033P01	1	34	SHELL SCREW	636C014P19	3
*5	SUPPORT RING	614C072P01	1	35	PLUNGER BUTTON	106C004P01	1
*6	MOUNT RING	614C059P02	1	36	"O" RING	614C027P01	2
*7	CUSHION MOUNT RING	469C004P02	1	37	BUSHING	102C003P02	1
8	OUTLET SCREW	636C017P03	2	38	"O" RING	614C028P01	1
9	OUTLET FLANGE	249C009P01	1	39	SCREW	636C026P01	4
10	OUTLET ELBOW	673C015P01	1	40	COLLAR	154C005P02	1
11	RUBBER OUTLET GASKET	269C038P01	1	41	SWITCH COVER	174C021P01	1
12	GRIND RING	614C060P01	1	42	SCREW	636C014P03	3
	DRAIN HOUSING ASSEMBLY - 100V	311C082S01	1	43	SCREW	636C019P01	2
	DRAIN HOUSING ASSEMBLY - 240V	311C082S21	1	44	CHERRY SWITCH - 100V, 220-240V	695C003P02	1
*13	DRAIN HOUSING	311C082P01	1	44	CHERRY SWITCH - 220-240V (BEAB ONLY)	695C003P03	1
*14	THRUST WASHER	789C041P01	1	45	SWITCH BRACKET	072C001P01	1
*15	WATER SEAL	645C006P01	1	46	JAM NUT	479C010P01	1
*16	SPACER SEAL	102C005P01	1	47	SPRING	675C001P01	1
17	SLINGER	789C034P03	1	48	WASHER	789C011P01	1
18	O-RING	645C005P01	1	49	WASHER	789C013P01	1
19	TURNTABLE ASSEMBLY	258C032S04	1	50	RETAINER	612C007P01	1
20	HOPPER	311C070S01	1	51	BUSHING	287C002P01	1
21	HOPPER SCREW	636C023P01	6	52	BUSHING	102C004P01	1
22	ADAPTER	614C061P02	1	53	CONNECTOR FLAG	711C010P01	2
23	GASKET	269C014P01	1	54	CONDUIT CLAMP	142C001P01	1
24	WASHER	789C035P02	1	55	SCREW	636C014P18	1
25	ARMATURE ASSEMBLY - 100V	626C035P07	1	56	CONDUIT	163C003P01	1
25	ARMATURE ASSEMBLY - 220-240V	626C038P03	1	57	LEAD WIRE	299C008P05	1
26	MOTOR STUD	687C003P05	2	58	LEAD WIRE	299C008P06	1
27	MOTOR SHELL ASSEMBLY - 100V	681C031S14	1	59	SPLICE	711C009P01	1
27	MOTOR SHELL ASSEMBLY - 220-240V	681C031S24	1	60	BUSHING	102C004P01	1
	ENDBELL ASSEMBLY - 100V	311C081S108	1	61	CONDUIT CLAMP	142C002P01	1
	ENDBELL ASSEMBLY - 220-240V	311C084S33	1	62	SCREW	636C014P18	1
	ENDBELL ASSEMBLY - 220-240V (BEAB ONLY)	311C084S33	1	†63	SINKFLANGE GASKET (THICK)	269C032P01	1
*28	ENDBELL - 100V	311C081X98	1	64	RFI FILTER - 100V	245C008S02	1
*28	ENDBELL - 220-240V	311C081X95	1	64	RFI FILTER - 220-240V	245C008S52	1
*29	MTR. BRUSH & BRUSH SPRING ASSY - 100V	027C029S02	1				
*29	MTR. BRUSH & BRUSH SPRING ASSY - 220-240-V	027C029S01	1				

†NOT SHOWN

*PART OF AN ASSEMBLY, BUT CAN BE PURCHASED SEPARATELY.

Anaheim Disposers

International 3/4 HP BATCH FEED

WKI-5000TC & GG BF950

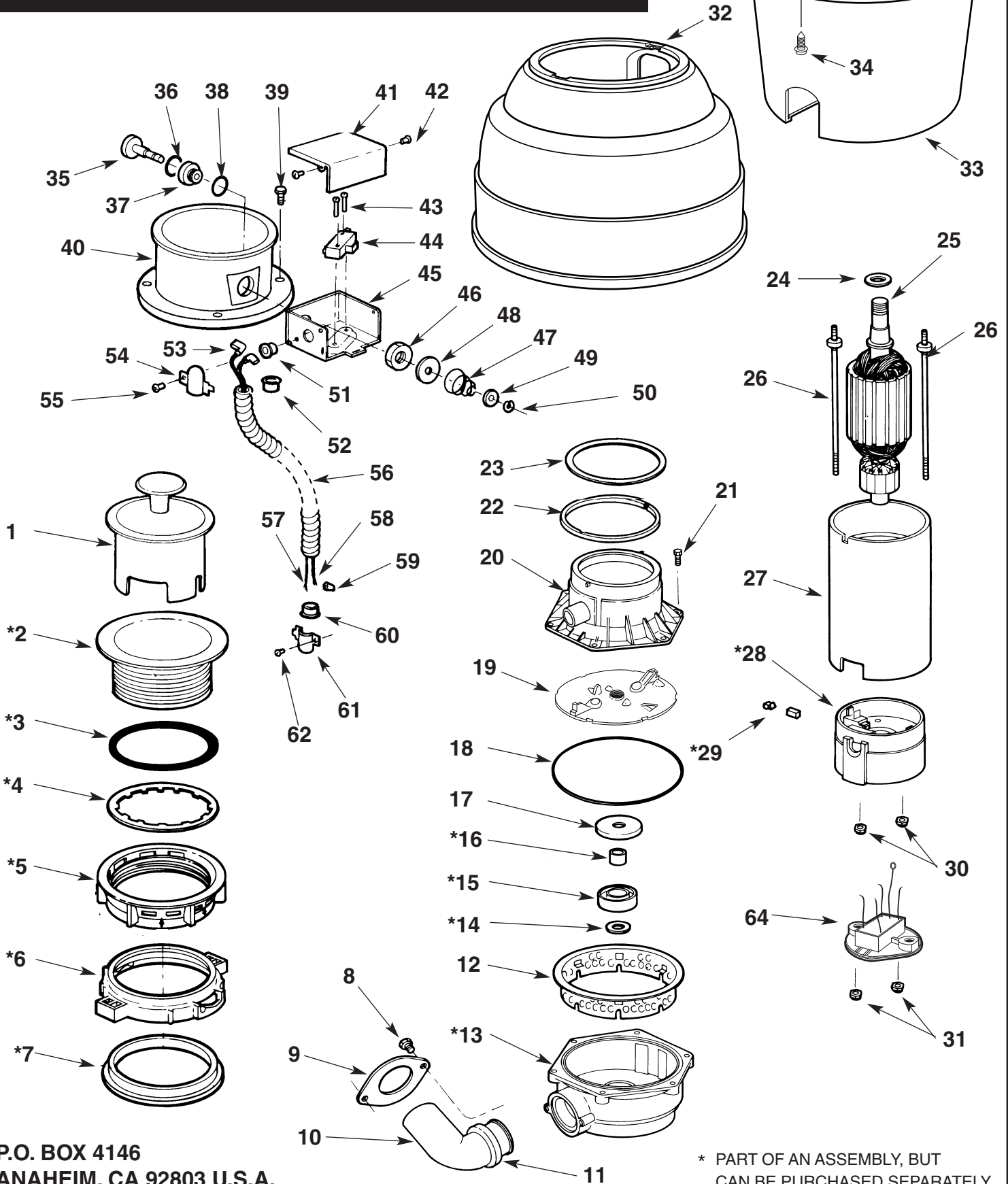

P.O. BOX 4146
ANAHEIM, CA 92803 U.S.A.

* PART OF AN ASSEMBLY, BUT
CAN BE PURCHASED SEPARATELY.

ITEM NO.	DESCRIPTION	WKI-8000 & GG 1050	QTY. PER UNIT
1	.STOPPER	.174C049S01	.1
MOUNT ASSEMBLY			
		.249C019S41	.1
*2	.SPLASH GUARD	.614C069P01	.1
*3	.SINK FLANGE & CAP ASSEMBLY	.249C014S01	.1
*4	.RUBBER GASKET	.269C031P01	.1
*5	.FIBER GASKET (WAXED)	.269C033P01	.1
*6	.SUPPORT RING	.614C072P01	.1
*7	.MOUNT RING	.614C059P02	.1
*8	.CUSHION MOUNT RING	.469C004P02	.1
9	.OUTLET SCREW	.636C017P03	.2
10	.OUTLET FLANGE	.249C009P01	.1
11	.OUTLET ELBOW	.673C015P01	.1
12	.RUBBER OUTLET GASKET	.269C038P01	.1
13	.GRIND RING	.614C060P01	.1
DRAIN HOUSING ASSEMBLY - 100V			
		.311C082S01	.1
DRAIN HOUSING ASSEMBLY - 220-240V			
		.311C082S21	.1
*14	.DRAIN HOUSING	.311C082P01	.1
*15	.THRUST WASHER	.789C041P01	.1
*16	.WATER SEAL	.645C006P01	.1
*17	.SPACER	.102C005P01	.1
18	.SLINGER	.789C034P03	.1
19	.O-RING	.645C005P01	.1
20	.TURNTABLE ASSEMBLY	.258C032S04	.1
21	.HOPPER	.311C070S01	.1
22	.HOPPER SCREW	.636C023P01	.6
23	.WASHER	.789C035P02	.1
24	.ARMATURE ASSEMBLY - 100V	.626C038P06	.1
24	.ARMATURE ASSEMBLY - 220-240V	.626C038P04	.1
25	.MOTOR STUD	.687C003P07	.2
26	.MOTOR SHELL ASSEMBLY	.681C031S25	.1
ENDBELL ASSEMBLY - 100V			
		.311CO84S26	.1
ENDBELL ASSEMBLY - 220-240V			
		.311CO84S34	.1
ENDBELL ASSEMBLY - 220-240V (BEAB ONLY)			
		.311CO84S34	.1
*27	.ENDBELL -100V	.311CO84S52	.1
*27	.ENDBELL -220-240V	.311CO84S52	.1
*28	.MOTOR BRUSH & BRUSH SPRING ASSEMBLY	.027C029S01	.1
29	.NUT	.479C019P01	.2
30	.NUT	.479C021P01	.2
31	.UPPER SHELL	.806C064P01	.1
32	.LOWER SHELL	.806C066P01	.1
33	.SHELL SCREW	.636C014P19	.3
†34	.SINK FLANGE GASKET-WAXED (THICK)	.269C032P01	.1
35	.RFI FILTER - 100V	.245C008S02	.1
35	.RFI FILTER - 220-240V	.245C008S53	.1

†NOT SHOWN *PART OF AN ASSEMBLY, BUT CAN BE PURCHASED SEPARATELY.

Anaheim Disposers

International 1 HP

WKI-8000 & GG 1050

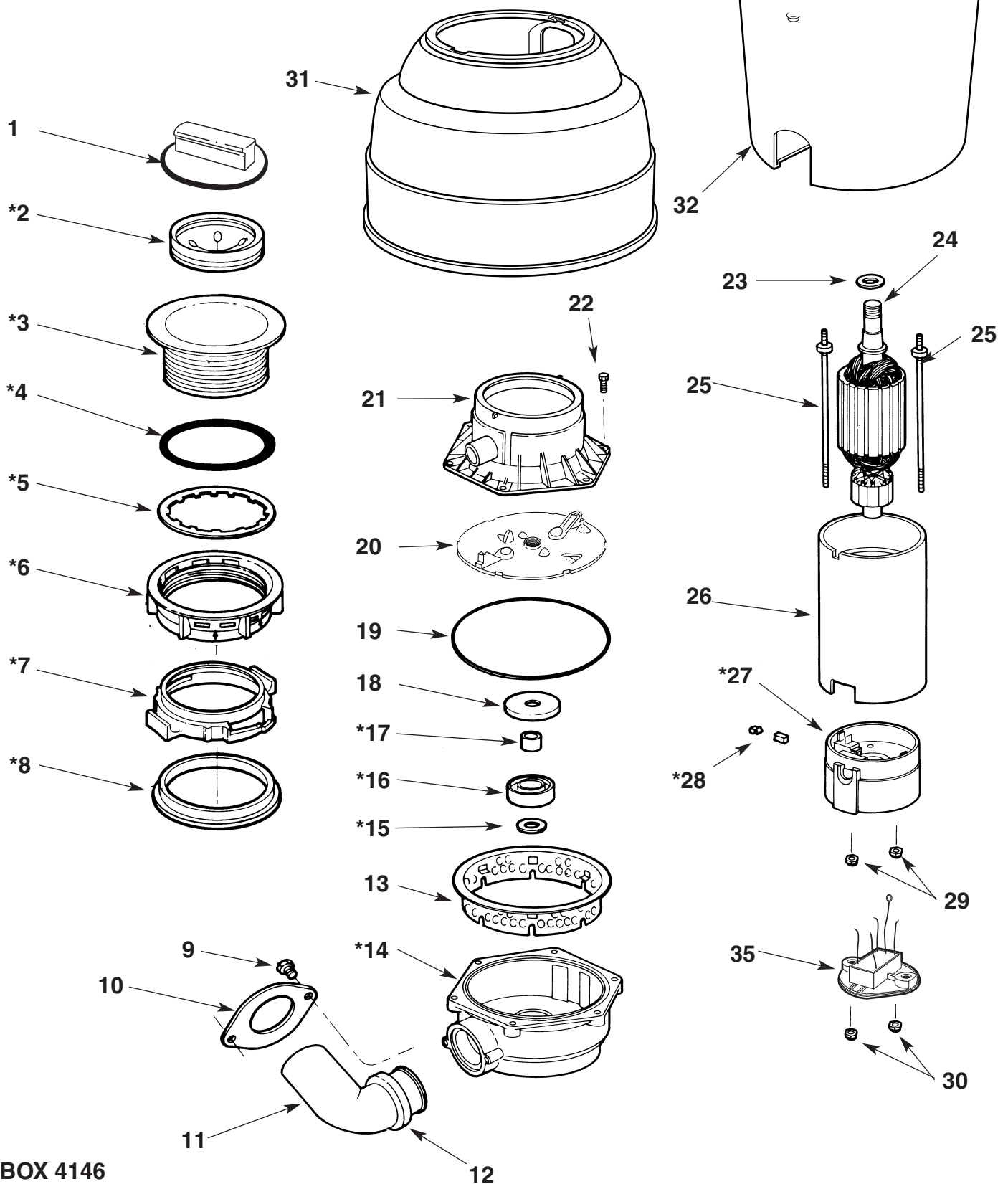

P.O. BOX 4146
ANAHEIM, CA 92803 U.S.A.

* PART OF AN ASSEMBLY, BUT CAN BE PURCHASED SEPARATELY.

WKI-8000TC & GG BF1050 BATCH FEED

ITEM #	DESCRIPTION	PART #	QTY	ITEM #	DESCRIPTION	PART #	QTY
	MOUNT ASSEMBLY	.249C019S75BF	.1	31	.NUT	.479C019P01	.2
*1	.STOPPER	.174C066S02	.1	32	.INSPECTION PLATE	.554C032P01	.1
*2	.SINKFLANGE & CAP ASSY.	.249C014S35	.1	33	.NUT	.479C021P01	.1
*3	.RUBBER GASKET	.269C031P01	.1	34	.UPPER SHELL	.806C064P51	.1
*4	.FIBER GASKET (WAXED)	.269C033P01	.1	35	.LOWER SHELL	.806C066P01	.1
*5	.SUPPORT RING	.614C072P01	.1	36	.SHELL SCREW	.636C014P19	.3
*6	.MOUNT RING	.614C059P02	.1	37	.PLUNGER BUTTON	.106C004P01	.1
*7	.CUSHION MOUNT RING	.469C004P02	.1	38	."O" RING	.614C027P01	.2
8	.OUTLET SCREW	.636C017P03	.2	39	.BUSHING	.102C003P02	.1
9	.OUTLET FLANGE	.249C009P01	.1	40	."O" RING	.614C028P01	.1
10	.OUTLET ELBOW	.673C015P01	.1	41	.SCREW	.636C026P01	.4
11	.RUBBER OUTLET GASKET	.269C038P01	.1	42	.COLLAR	.154C005P02	.1
12	.GRIND RING	.614C060P01	.1	43	.SWITCH COVER	.174C021P01	.1
	DRAIN HOUSING ASSEMBLY - 100V	.311C082S01	.1	44	.SCREW	.636C014P03	.3
	DRAIN HOUSING ASSEMBLY - 220-240V	.311C082S21	.1	45	.SCREW	.636C019P01	.2
*13	.DRAIN HOUSING	.311C082P01	.1	46	.CHERRY SWITCH	.695C003P02	.1
*14	.THRUST WASHER	.789C041P01	.1	47	.SWITCH BRACKET	.072C001P01	.1
*15	.WATER SEAL	.645C006P01	.1	48	.JAM NUT	.479C010P01	.1
*16	.SPACER SEAL	.102C005P01	.1	49	.WASHER	.789C011P01	.1
	TURNTABLE ASSEMBLY	.258C032S04	.1	50	.SPRING	.675C001P01	.1
*17	.SLINGER	.789C034P03	.1	51	.WASHER	.789C013P01	.1
*18	.O-RING	.645C005P01	.1	52	.RETAINER	.612C007P01	.1
*19	.TURNTABLE	.258C032P02	.1	53	.BUSHING	.287C002P01	.1
20	.HOPPER ASSEMBLY	.311C070S01	.1	54	.BUSHING	.102C004P01	.2
21	.HOPPER SCREW	.636C023P01	.6	55	.CONNECTOR FLAG	.711C010P01	.2
22	.ADAPTER	.614C061P02	.1	56	.CONDUIT CLAMP	.142C001P01	.1
23	.GASKET	.269C014P01	.1	57	.GROUND WIRE ASSEMBLY	.299C005S08	.1
24	.WASHER	.789C035P02	.1	58	.CONDUIT	.163C003P01	.1
25	.ARMATURE ASSEMBLY - 100V.	.626C035P16	.1	59	.LEAD WIRE (WHITE)	.299C008P06	.1
25	.ARMATURE ASSEMBLY - 220-240V	.626C038P04	.1	60	.LEAD WIRE (WHITE)	.299C008P11	.1
26	.MOTOR STUD	.687C003P05	.1	61	.SPLICE	.711C009P01	.1
27	.MOTOR STUD	.687C003P06	.1	62	.GROUND SCREW	.636C027P01	.1
28	.MOTOR SHELL ASSEMBLY	.681C031S25	.1	63	.CONDUIT CLAMP	.142C002P01	.1
	ENDBELL ASSEMBLY - 100V	.311C084S27	.1	64	.SCREW	.636C014P18	.1
	ENDBELL ASSEMBLY - 240V	.311C084S36	.1	†65	.SINKFLANGE GASKET (THICK)	.269C032P01	.1
*29	.ENDBELL	.311C081P01	.1	†66	.RFI FILTER	.245C008S02	.1
*30	.MTR. BRUSH & BRUSH SPRING ASSY	.027C029S02	.1	†66	.RFI FILTER	.245C008S53	.1

†NOT SHOWN

*PART OF AN ASSEMBLY, BUT CAN BE PURCHASED SEPARATELY.

Anaheim Disposers

International 1 HP BATCH FEED WKI-8000TC & GG BF1050

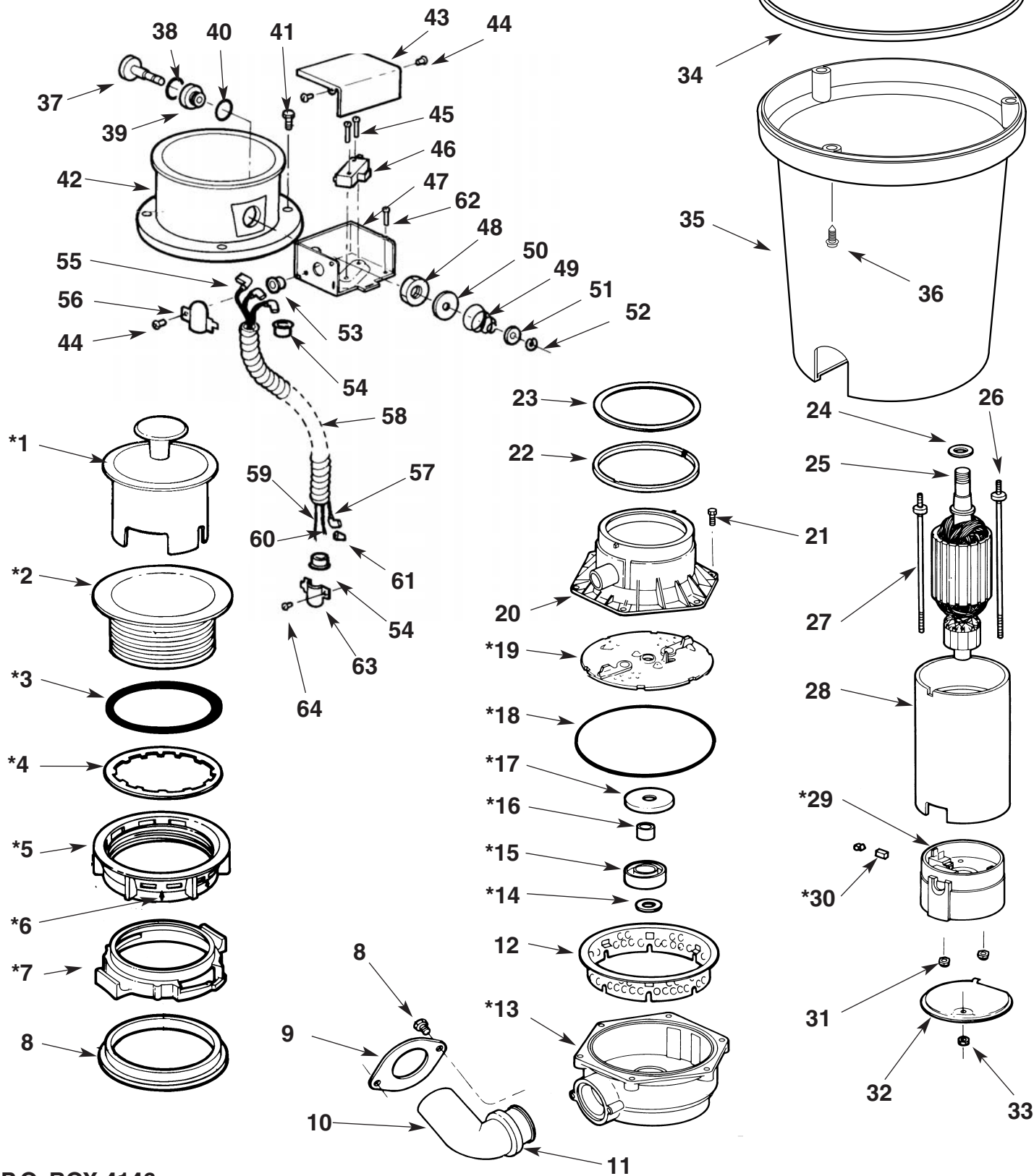

P.O. BOX 4146
ANAHEIM, CA 92803 U.S.A.

* PART OF AN ASSEMBLY, BUT CAN BE PURCHASED SEPARATELY.